

TENDER NO.: S-CEM/OTE/MCAD/3043/141-1/2020-2021/10666

TENDER DOCUMENT

**SUB: SUPPLY AND INSTALLATION OF MILLIMETER-WAVE (60 GHz)  
MEASUREMENT SYSTEM**

DUE ON

: 12.03.2021 at 14.00 Hrs.



SOCIETY FOR APPLIED MICROWAVE ELECTRONIC  
ENGINEERING AND RESEARCH

(An Autonomous R&D Institution under the Ministry of Electronics &  
Information Technology, Govt. of India)

SAMEER- Centre for Electromagnetics,  
CIT Campus, 2nd Cross Road, Taramani, Chennai-600 113

Phone No: (044)22541583/1817/22544020/4061

(Fax). (044) 2254 1938/ 1424

Website: <http://cem.sameer.gov.in>

E-mail: [purchase.chn.sameer@nic.in](mailto:purchase.chn.sameer@nic.in)

## INDEX

SR.NO	TITLE	PAGE NO
1	Notice Inviting Tender (NIT) and Index	3-4
2	Instructions to Bidder (ITB) for submission of bid etc., and Terms & Conditions	
	A. Eligibility/Qualification Criteria	5-6
	B. The Bidding Documents	6-7
	C. Preparation of Bids	7-13
	D. Submission of Bids	13
	E. Opening & Evaluation of Bids	14-19
	F. Payment Terms	20
	G. Penalty Clause	21-22
3	Technical Bid	22-24
4	Price Bid	25
5	Annexure-I: Manufacturer's Authorization Letter	26
6	Annexure-II: Bidder's Performance Statement Form	27
7	Annexure-III: Service Support Details Form	28
8	Annexure-IV: Deviation Statement Form	29
9	Annexure-V: Technical Specification Compliance Statement Form	30
10	Annexure-VI: TENDER ACCEPTANCE LETTER	31-32
11	Annexure-VII: Eligibility of Bidder	33
12	Bid (EMD) security Declaration Form	34

NOTICE INVITING TENDER(NIT)  
(Submission of Tender in Two Bid Format)

Sealed Tenders are invited under Two Bid (Technical & Commercial) from reputed Equipment Manufactures / Indian Authorized Agents of Foreign Suppliers for the supply of Scientific Equipment as mentioned below

1.	Description of Item	One	Cost of Tender
	<b>SUPPLY AND INSTALLATION OF MILLIMETER-WAVE (60 GHz) MEASUREMENT SYSTEM</b>		<b>(In Indian Rupees) 1,500/- + 18 % GST(Rupees one thousand and five hundred only)</b>

Tender Documents can be downloaded from SAMEER-CEM website<<http://cem.sameer.gov.in>> and CPPP website<<https://eprocure.gov.in/cppp/>>

**IMPORTANT DATES & TIME**

Last date and time of Submission of bids by the prospective bidders in Two Bid Format	<b>12.03.2021 14.00 hrs.</b>
Date and Time of Opening of Technical Bids	<b>12.03.2021 at 15.30 hrs.</b>
Venue of Opening of Bids	SAMEER-CEM, Taramani,Chennai - 600 113
Tenders to be submitted at	Security Gate, SAMEER-CEM,CIT Campus, 2 <sup>nd</sup> Cross Road, Taramani,Chennai - 600 113

**IMPORTANT NOTE:**

- Please strictly adhere to the dates/times mentioned in this document.
- The bid will be opened in the presence of bidders/representatives. If any unscheduled holiday occurs on the date of submission/opening, then next working day shall be prescribed as date of submission/opening.
- Prospective bidders are requested to submit their offers in **Two-Bid format** only as per tender documents.
- Requests for postponement of date and time of submission and opening of bids will not be entertained.
- Fax/email bids will not be accepted.
- Late/Delayed bids shall not be opened.
- Please send your bids to the Programme Director the address mentioned above

**INSTRUCTIONS TO BIDDER (ITB) FOR SUBMISSION OF BID etc.,**  
**AND TERMS & CONDITIONS**

**SECTION-A ELIGIBILITY/QUALIFICATION CRITERIA**

**1. Eligible Bidders**

**1.1** Bids are invited from manufacturers or their dealers specifically authorized by the manufacturers to quote on their behalf for this tender and Indian agent of foreign principals, if any who have designed, manufactured, tested and supplied the equipment(s) similar to the type specified in the "Technical Specification". Such equipment's must be of the new and most recent series/models, incorporating the latest improvements in design. Only new equipment's shall be quoted/supplied and refurbished equipments shall not be quoted/supplied. The equipment and accessories quoted must be from original manufacturer and must be first purchased (No second-hand item/sub-item will be accepted).

**1.2** Either the Indian Agent on behalf of the Principal/OEM or Principal/OEM itself can bid, but both cannot bid simultaneously for the same item/product in the same tender.

**1.3** If an agent submits bid on behalf of the Principal/OEM, the same agent shall not submit a bid on behalf of another Principal/OEM in the same tender for the same item/ product.

**1.4** In case a foreign bidder who does not have an agent in India quotes, then the foreign principal shall have to furnish a certificate to the effect that the bidder is or will be represented by an agent in India equipped and able to carry out the supply, maintenance, repair obligations etc. during the warranty and post-warranty period or ensure a mechanism at place for carrying out the supply, maintenance, repair obligations etc. during the warranty and post-warranty period. In case the foreign suppliers themselves would provide service during warranty then their service visit plan for mandatory visits and for breakdown visits may be provided.

**1.5** Details of service support facilities that would be provided after the warranty period should be submitted in the Service Support Details Form.

**1.6** That adequate and specialized expertise is already available or will be made available following the execution of the contract in INDIA, to ensure that the support services are responsive and adequate.

**1.7** That the Bidder will assume total responsibility for the fault-free operation of equipment, application software, if any, and maintenance during the warranty period and provide necessary maintenance services and availability of spares for ten years after end of warranty period if, required.

**1.8** In order to assess the financial solvency of a firm, Programme Director,

SAMEER-CEM may seek a report from the bankers of the technically evaluated lowest quoting firm in order to assess if the firm is financially capable of executing the purchase order/work successfully.

**1.9** Bidders who meet the criteria given above are subject to be disqualified, if they have made untrue or false representation in the forms, statements and attachments submitted in proof of the qualification requirements or have a record of poor performance, not properly completing the contract, inordinate delays in completion or financial failure, etc.,

**1.10** If before/after the placement of the Purchase Order it is found/noticed that the supplier has been black-listed/debarred then such supplier will be dropped from the tendering process as technically not suitable to quote or order will be cancelled. Thus, black-listed/debarred firms are requested not to participate in our tendering process.

**1.11** Any additional bid participation criteria/eligibility conditions etc. mentioned in the Technical Specification sheet will also form part of the Qualification Requirements along with those mentioned in this chapter.

## **SECTION-B: THE BIDDING DOCUMENTS**

### **2 Cost of Bid Document**

Tender document can be purchased from the Accounts Section of SAMEER-CEM located at CIT Campus, 2<sup>nd</sup> Cross Road, Taramani, Chennai – 600 113 between 10.00 AM and 5.00 PM, on cash payment of Rs. 1500/-+18% GST (Rupees One thousand five hundred only) on all days except Saturdays, Sundays and public holidays. If the tender document is downloaded from our website <<http://cem.sameer.gov.in>>or <<https://eprocure.gov.in/cppp>>, then Tender fee should be paid along with Technical Bid (EMD & Tender Fee should be paid separately)

### **3. Contents of Bid Document**

The goods required, bidding procedures and contract terms are prescribed in this bid document which includes the following:

**3.1** The Bidder is expected to examine all instructions, forms, terms and conditions and specifications in the bidding documents. Failure to furnish all information required by the bidding documents or submission of a bid not substantially responsive to the bidding documents in every respect will be at the Bidder's risk and shall result in rejection of the bid.

### **4. Amendment to Bid Document**

**4.1** At any time prior to the deadline for submission of bids, SAMEER-CEM may, for any reason, whether at its own initiative or in response to a clarification requested by a prospective bidder, modify the Bid Document by amendment. Such amendments shall form an integral part of bid documents and it shall amount to an amendment of relevant clauses of the Bid Document.

**4.2** The prospective bidders are required to keep a watch on the SAMEER-CEM website <<http://cem.sameer.gov.in>> for any amendment to the tender document or to clarification to the queries raised by the bidders till 01 (one) day prior to the opening of the tender. SAMEER-CEM reserves the right to reject the bids if the bids are submitted without taking into account these amendments/ clarifications. Further, bidders will be fully responsible for downloading the tender document and amendments thereto if, any for their completeness.

**4.3** In order to allow prospective bidders to take reasonable time in which to effect the amendment into account in preparing their bids, SAMEER-CEM, at its discretion, may also extend the deadline for the submission of bids.

## **SECTION - C. PREPARATION OF BIDS**

### **5. Language of Bid**

The Bid prepared by the Bidders and all correspondence and documents relating to the bid exchanged by the bidder shall be written in English language only.

### **6. Documents Comprising the Bid**

**6.1** The bid is required to be submitted **in two Bid Format**. The bidders shall submit their bids in sealed covers (Tender No. & Due date must be compulsorily mentioned on the envelope containing the bid)

**6.2** Detailed Specifications, Catalogues, List of users & Technical Details, Technical Compliance Sheet Pre-Installation Requirements, payment terms, warranty terms etc., must be submitted along with technical bid.

### **6.3 Technical Bid shall include the following**

- (i) Bid (EMD) security declaration form
- (ii) Tender fee as specified in the invitation to bids
- (iii) Service Support Details Form
- (iv) Deviation Statement Form
- (v) Technical Specification Compliance Statement Form
- (vi) Manufacturer's Authorization Letter

- (vii) Bidder's Performance Statement Form
- (viii) Equipment Data sheet/Technical specification
- (ix) Tender Acceptance Letter-Annex-VII (*duly signed by the bidder with company seal*).
- (x) Bidders Eligibility Certificate-Annex-VIII (*duly signed by the bidder with company seal*)

## 7. Prices

**7.1** The Bidder shall indicate the unit price and total price of the goods it proposes to supply under the order and enclose it with the price bid. SAMEER-CEM is a Govt funded R&D centre. Please consider quoting special prices applicable to R&D institutions as per your company policies.

**7.2** Full Prices in Foreign Currency or in Indian Rupees may be given in the bid for -

- (i) Main Equipment.
- (ii) Essential Accessories & Spares.

**7.3 Prices indicated shall be entered separately in the following manner (For Indigenous and Imported Items):**

- i. The price of the equipment shall be quoted on ex-works, ex-factory, ex-showroom, ex-warehouse, or off-the-shelf, as applicable.
- ii. **Custom Duty : SAMEER-CEM** SAMEER-CEM is registered with Department of Scientific and Industrial Research (DSIR) for the purpose of availing custom duty exemption in terms of Government of India Notification No. 51/96-customs amended to 24/2007- customs dated 1st March 2007. **{approx. 5.20 % duty is applicable under this notification (5% Basic + cess/surcharge)}** and central excise duty exemption in terms of Government Notification no. 10/97-central excise amended to 16/2007-central excise dated 1st March 2007.
- iii. **GST:** Concessional GST (5%)Rates will be applicable to SAMEER-CEM as per GOI, Ministry of Finance, Notification No. 47/2017-Integrated Tax (Rate) dt. 14/11/2017. It is certified that SAMEER-Centre for Electromagnetics is an Autonomous Institute of the Ministry of Electronics & Information Technology, Govt. of India and it is registered with the (DSIR) Department of Scientific & Industrial Research, Government of India vide their Registration No. F.No.11/354/1997/-TU-V dated 18th March 2019, Valid up to 31.03.2022. It is also certified that the material/goods purchased is required for Research & Development in SAMEER-CEM. Duly signed GST concessional Certificate will be provided along with PO
- iv. We don't issue any 'Form C' or 'Form D'.
- v. If there is no explicit mention of taxes in your offer, then quoted price will



be *deemed inclusive* of such taxes. **No other charges except those mentioned clearly in the price bid will be paid.**

- vi. Packing, forwarding, documentation, freight and insurance charges and installation charges must be clearly mentioned separately. Vague terms like “packing, forwarding, transportation etc., extra” without mentioning the specific amount/percentage of these charges will NOT be accepted. Such offers shall be treated as incomplete and rejected.

## 8. Training

The supplier should provide detailed onsite training at SAMEER-CEM Chennai after installations of the said equipment at SAMEER-CEM free of cost. This training shall be to the satisfaction of SAMEER-CEM Scientists.

## 9. Installation

**9.1** Installation will be the sole responsibility of the Supplier / Indian Agent. Installation with all infrastructural works have to be done by the supplier. The vendor /Indian Agent will complete the installation within **15 days** from the date of supply of equipment to SAMEER-CEM.

**9.2 Pre-requisite for installation: The bid must include pre-requisite for installation of the equipment at SAMEER-CEM.**

## 10. Warranty

The Supplier must warrant that the goods supplied under the Contract are new, unused and the most recent or current and incorporate all recent improvements in design, materials as per specifications in this Tender Document. All Vendors (Manufacturers / Agents) must submit offers with at least 3 **(three) years comprehensive and onsite warranty** after successful installation of the equipment in all respects at Site, i.e., SAMEER-CEM, Chennai (**which would be considered for the tender evaluation purpose**). The successful installation date along with the date to be reckoned for start of the warranty period needs to be certified by the vendor & the user scientist. **The warranty offered should be unconditional and the seller should agree to replace or repair the equipment at his cost. The spare parts for the warranty repair have to be provided by the vendor.**

All costs /expenses incurred towards repair/service during warranty period (like courier/Freight, Insurance, Customs etc) shall be reimbursed/borne by supplier / manufacturer to SAMEER. Alternatively, supplier / manufacturer shall take up the total responsibility of courier/Freight, Insurance, Customs etc. for repair/service during warranty period.

## 11. Delivery Period:

- a) In case of **foreign suppliers, the firm delivery of period is 12 weeks after opening irrevocable Letter of Credit (LC)**. No part shipment is permitted.
- b) In case of **Indigenous suppliers, the firm delivery period is 12 weeks after issue of Purchase Order**. Delivery is to be made at SAMEER-CEM, Chennai. Delivery must be on FREIGHT PAID BASIS for despatch by Road.
- c) The bidder must provide information regarding mode of shipment whether it is by **Air/Sea/Road/Rail**.

## 12. Bid Currencies

Prices shall be quoted in Indian Rupees (INR) or in freely convertible foreign currency preferably in **USD (\$), Euro (€), Yen (¥), GBP (£) and SFr (CHF)** wherever possible for correct evaluation during comparison.

## 13. Documents Establishing Bidder's Eligibility and Qualifications

The bidder shall furnish, as part of its bid, documents establishing the bidder's eligibility to bid and its qualification to perform the contract if the bid is accepted.

### 13.1. Documents Establishing Goods' Eligibility and Conformity to Bid Document

**13.2** The documentary evidence of the equipment eligibility shall consist of a statement on the **country of origin** of the goods and services offered which shall be confirmed by a **certificate of origin at the time of shipment**.

**13.3** Specifications are basic essence of the product. It must be ensured that the offers are strictly as per our tendered specifications. At the same time, it must also be kept in mind that merely copying our specifications in their quotation shall not make firms eligible for consideration. The documentary evidence of conformity of the equipment to the Bid Document may be in the form of literature, drawings and data, and shall consist of:

- (i) A detailed description of the essential technical and performance characteristics of the equipment;
- (ii) A list giving full particulars, including available sources and current prices, of spare parts, special tools, etc., necessary for the proper and continuing functioning of the goods for a period of 10 years, following commencement of the use of the goods by the Purchaser; and

(iii) An item-by-item commentary on the SAMEER-CEM Technical Specifications demonstrating substantial responsiveness of the goods and services to those specifications or a statement of deviations and exceptions to the provisions of the Technical Specifications.

#### **14. Period of Validity of Bids**

Bids must remain valid for at least **180 days** after the date of bid opening prescribed by **SAMEER-CEM**. A bid valid for a shorter period may be rejected by the Purchaser as non-responsive.

**14.1** In exceptional circumstances, SAMEER-CEM may solicit the Bidder's consent to an extension of the period of validity. The request and the responses thereto shall be made in writing (fax or e-mail). The bid security shall also be suitably extended, if applicable.

**14.2** Bid evaluation will be based on the bid prices without taking into consideration the above corrections.

#### **15. Patent Right & IPR Laws:**

The supplier shall indemnify SAMEER-CEM against all third-party claims of infringement of Patent, Trademark or Industrial Design Rights arising from the use of Goods or any part thereof in the Purchaser's country (INDIA). The vendor should be sure about his claim on the ownership of technology and total compensation in the event of a claim should be paid to the buyer in case of patent infringement.

#### **16. Right to Information Act.2005**

The tenderer may indicate if any information in his tender includes information of commercial confidence, trade secrets or intellectual property, the disclosure of which would harm the competitive position of your company.

#### **17. Format of Bid**

The tenders are invited on two bid systems i.e. the qualifying bid (technical bid including tender fee) and then the price bid:

**17.1** The tender form for Technical bids shall be complete in all respects should be submitted in sealed cover superscripted - "**Technical Bid – Supply & Installation of Millimeter-wave (60 GHz) Measurement System**"

**17.2** The tender form for price bid shall be complete in all respects should be

submitted in sealed cover superscribed – “**Price Bid –Supply& Installation of Millimeter-wave (60 GHz) Measurement System**”

**17.3** The above two sealed covers should be put together in another big cover/envelope which should be sealed with wax. The cover shall be superscribed as “Tender No:....., dated: ..... & Name of Tender “**Supply& Installation of Millimeter-Wave(60 GHz) Measurement System**” and addressed to

The Programme Director,  
Society for Applied Microwave Electronics Engineering and Research(SAMEER)  
Centre for Electromagnetics, CIT Campus, 2nd Cross Road,  
Taramani,  
Chennai - 600 113, Tamil Nadu, India.

**17.3** Further, the sentence “NOT TO BE OPENED” before due date and time of tender opening, should also to be indicated on this envelope. If the outer big envelope is not sealed and marked properly as above, SAMEER will not take any responsibility for its misplacement, premature opening etc. The bid document shall be submitted in the above mentioned address latest by 14.00 hrs. on 12.03.2021.

**17.4** The original and all copies of the bid shall be typed or written in indelible ink and shall be signed by the Bidder or a person or persons duly authorized to bind the Bidder to the Contract. All pages of the bid, except for un-amended printed literature, shall be initialled /endorsed by the person or persons signing the bid.

**17.5** Any interlineations, erasures or overwriting shall be valid only if the persons or persons signing the bid initial them.

**17.6** The Bidder shall furnish information on commissions or gratuities, if any paid or to be paid to agents relating to this Bid, and to contract execution if the Bidder is awarded the contract as per the bid form.

## **18. Deadline for Submission of Bids**

**18.1** Bids must be received at SAMEER-CEM in the address specified not later than the time and date specified in the NIT. In the event of the specified date for the submission of Bids being declared a holiday for SAMEER-CEM, the Bids will be received up to the appointed time on the next working day.

**18.2** SAMEER-CEM may, at its discretion, extend this deadline for submission of bids by amending the bid documents.

## **19 Late Bids**

Any bid received after the deadline for submission of bids prescribed by SAMEER-CEM, will be rejected and/or returned to the Bidder.

## **20. Modifications and Withdrawal of Bids**

The Bidder may modify or withdraw its bid after the submission of bid provided that written notice of the modification or withdrawal is received by SAMEER-CEM prior to the deadline prescribed for submission of bids.

**20.1** No bid may be modified subsequent to the deadline for submission of bids.

**20.2** No bid may be withdrawn in the interval between the deadline for submission of bids and the expiration of the period of bid validity specified by the Bidder on the bid form. Withdrawal of a bid during this interval may result in the Bidder's forfeiture of its bid security

### **SECTION- E: OPENING AND EVALUATION OF BIDS**

## **21. Opening of Bids by the Purchaser**

**21.1** SAMEER-CEM through its "TENDER OPENING COMMITTEE (TOC)" will open bid in the presence of Bidders/representatives who choose to attend, as per the schedule given in invitation to bids.

**21.2** Bidders interested in participating in the bid opening process, should depute their representatives along with an authorization letter to be submitted to SAMEER-CEM (Tender Opening Committee) at the time of bid opening as mentioned in the NIT.

**21.3** The Bidders' representatives who are present shall sign the bid opening attendance sheet evidencing their attendance. In the event of the specified date of Bid opening being declared a holiday for SAMEER-CEM, the Bids shall be opened at the appointed time and location on the next working day.

**21.4** The bidder's names, bid modifications or withdrawals, specifications, and the presence or absence of requisite bid security and such other details, TOC at its discretion, may consider appropriate, will be announced at the bid opening meeting.

**22. Bids that are received late shall not be considered for further evaluation, irrespective of the circumstances.**

23. Any correction in the price quoted in the tender in words and/or figures shall be encircled in red ink by the bidders/representative and signed. The members of the tender opening committee shall endorse this.

#### **24. Clarification of Bids**

24.1 To assist in the examination, evaluation and comparison of bids, the Purchaser may, at its discretion ask the bidder for any clarification(s) of its bid/offer. The request for clarification and the response shall be in writing and no change in the prices or substance of the bid shall be sought, offered or permitted. **However, no post Bid clarifications at the initiative of the Bidder shall be entertained/considered.**

24.2 Any clarification and confirmation from the vendor after opening of the bid should not result in modification of their original offer in order to suit or meet the tendered specifications which would not be considered and accepted. Technical evaluation will be done strictly as per the details mentioned by the vendor in original offer with respect to the tendered specifications of SAMEER-CEM.

24.3 Any item not quoted in their original offer will not be accepted even though the party is willing to provide the materials + the unmentioned items at the same cost.

24.4 Any confirmation/clarification/modification by the bidder against the letter from SAMEER-CEM for communicating them the technical points of rejection would not make the firm technically suitable and their offer will stand as technically rejected. **Technical evaluation will be done strictly as per original offer submitted by the vendor with respect to the tendered specifications of SAMEER-CEM.**

#### **25. Preliminary Examination**

25.1 The TOC will examine the bids to determine whether they are complete, whether required tender fee and EMD have been furnished, whether the documents have been properly signed, and whether the bids are generally in order.

25.2 The TOC shall examine the bids to confirm that all documents and technical documentation as requested have been provided, and to determine the completeness of each document submitted

(a) All the tenders received will first be scrutinized to see whether the tenders meet the basic requirements as incorporated in the NIT. The tenders, which do not meet the basic requirements, are to be treated as unresponsive and ignored. The following are some of the important points, for which a tender may be declared as unresponsive and to be ignored, during the initial scrutiny:

- (i) The Bid is unsigned.
- (ii) The Bidder is not eligible.
- (iii) Tender fee is not submitted.
- (iv) The Bid validity is shorter than the required period.
- (v) The Bidder has quoted for goods manufactured by a different firm without the required authorization letter from the manufacturer/OEM.
- (vi) Bidder has not agreed to give the required performance security.
- (vii) The goods quoted are sub-standard, not meeting the required specification etc.
- (viii) Against the schedule of Requirement (incorporated in the tender enquiry), the tenderer has not quoted for the entire requirement as specified in that schedule.
- (ix) The tenderer has not agreed to some essential condition(s) incorporated in the tender enquiry.

**26.** Prior to the detailed evaluation, the TOC will determine the substantial responsiveness of each bid to the bidding documents. For purposes of this clause, a substantive responsive bid is one, which conforms to all terms and condition of the bidding documents without material deviations, reservations or omissions. A material deviation, reservation or omission is one that:

- (a) affects in any substantial way the scope, quality or performance of the equipment and Related Services specified in the Contract; or
- (b) limits in any substantial way, inconsistent with the Bidding Documents, the Purchaser's rights or the Bidder's obligations under the Contract ; or
- (c) If rectified, would unfairly affect the competitive position of other bidders presenting substantially responsive bids.

**26.1** The TOC determination of a bid's responsiveness is to be based on the contents of the bid itself without recourse to extrinsic evidence.

**26.2** If a bid is not substantially responsive, it will be rejected by the TOC and may not subsequently be made responsive by the Bidder by correction of the material deviation, reservation or omission.

## **27. Non-conformities between the figures and words of the quoted price**

**27.1** Any discrepancy between quoted prices in figures and that in words, if noted will be sorted out in the following manner:

- (a) If there is a discrepancy between the unit price and the total price (which is obtained by multiplying the unit price by the quantity), the unit price shall prevail and the total price corrected accordingly, unless in the opinion of the TOC there is an obvious misplacement of the decimal point in the unit price, in which case the total price as quoted shall govern and the unit price corrected accordingly.

(b) If there is an error in a total corresponding to the addition or subtraction of subtotals, the subtotals shall prevail and the total shall be corrected.

(c) If there is a discrepancy between words and figures, the amount in words shall prevail, unless the amount expressed in words is related to an arithmetic error, in which case the amount in figures shall prevail subject to (a) and (b) above.

27.2 If there is such discrepancy in a bid, the same is to be conveyed to the bidder with target date on the above lines and if the bidder does not agree to the observation of the TOC, the tender is liable to be ignored and its Bid Security may be forfeited.

## **28. Non-conformity, Error and Omission**

28.1 Provided that a Bid is substantially responsive, the TOC may waive any non-conformities or omissions in the Bid that do not constitute a material deviation.

28.2 Provided that a bid is substantially responsive, the TOC may request that the Bidder submit the necessary information or documentation, within a reasonable period of time, to rectify nonmaterial nonconformities or omissions in the bid related to documentation requirements. Such omission shall not be related to any aspect of the price of the Bid. Failure of the Bidder to comply with the request may result in the rejection of its Bid.

## **29. Examination of terms & Conditions, technical Evaluation**

29.1 The TOC shall examine the Bid to confirm that all terms and conditions specified in the tender document have been accepted by the Bidder without any material deviation or reservation including the terms & conditions mentioned.

29.2 Prior to the detailed evaluation, the TOC determine the *substantial responsiveness* of each bid to the Bid Document as mentioned. Deviations from or objections or reservations to critical provisions such as those concerning Bid Security/ Performance Security, Warranty, Taxes& Duties will be deemed to be a material deviation. The Purchaser's determination of a bid's responsiveness is to be based on the contents of the bid itself without recourse to extrinsic evidence.

29.3 TOC shall evaluate the technical aspects of the Bid submitted to confirm that all requirements specified in Schedule of Requirement of the Bidding Documents have been met without any material deviation or reservation.

29.4 If, after the examination of the terms and conditions and the technical evaluation with respect to the tendered technical specification of SAMEER-CEM, the Purchaser determines that the Bid is not substantially responsive in accordance with ITB, it shall reject the Bid.

29.5 SAMEER-CEM may waive any minor informality, non-conformity, or



irregularity in a bid, which does not constitute a material deviation, provided such a waiver, does not prejudice or affect the relative ranking of any Bidder.

**29.6** After downloading, the language of standard clauses etc. mentioned in this 'Bid Document' should not be tampered with/ changed/modified in any manner whatsoever. If any such modification etc. comes to our knowledge at any stage, the bid shall be rejected immediately and EMD shall also be forfeited.

### **30. Evaluation & Comparison of Bids.**

**30.1 Conversion to Single Currency:** -To facilitate evaluation and comparison, the TOC will convert all bid prices expressed in the amounts in various currencies in which the bid prices are payable to Indian Rupees at the selling exchange rate established by the Reserve Bank of India <[www.rbi.org](http://www.rbi.org)> prevailing rate on the date of opening the Price bid.

**30.2** For the bids surviving the technical evaluation which have been found to be substantially responsive shall be evaluated and compared.

**30.3** To evaluate a Bid, the TOC shall only use all the factors, methodologies and criteria defined below. No other criteria or methodology shall be used.

#### **30.4 PROCESS OF EVALUATION (BETWEEN INR QUOTE & FOREIGN CURRENCY QUOTE): -**

**(a)** The bids shall be evaluated on the basis of ex-works. The bidders should submit their quote as per the tender document which should be as follows.

##### **(b) For goods manufactured in India: -**

(i) The price of the equipment shall be quoted on FOR SAMEER-CEM, Chennai, as specified in the bidding document.

(ii) GST and other taxes like excise duty etc., which will be payable on the goods of the contract is awarded. SAMEER-CEM is not entitled for issuing C&D form.

(iii) All Charges involved for inland transportation, insurance, Road Permit if required for delivering the goods at the desired destination i.e., F.O.R, SAMEER-CEM, Chennai, Tamil Nadu.

(iv) The installation, training, accommodation and travel charges if any

##### **(c) The goods manufactured in abroad: -**

(i)The price of the equipment shall be quoted on the basis Ex-works, as specified

in the bidding document.

(ii) Installation & Training charges if any.

### **30.5 PROCESS OF EVALUATION (BETWEEN INR QUOTE & FOREIGN CURRENCY QUOTE):-**

**30.6** The comparison between the indigenous and the foreign offers shall be made on Ex-works basis.

a) In case, where the foreign principal quotes and he does not have an agent in India then the foreign service engineer visits and AMC charges should be provided. The foreign service engineer's visit during installation would be added for the purpose of cost comparison and selection

### **30.7 PROCESS OF EVALUATION: (BETWEEN TWO OR MORE FOREIGN CURRENCY QUOTE):-**

SAMEER-CEM shall evaluate the bids for deciding a technically suitable lowest quoting would be on Ex-works.

**30.8** If the bidder quoted certain optional items, these items should not be taken into consideration for the evaluation of the bid unless the specifications of the optional item quoted by the bidder are part of original indented specification.

## **31. Contacting SAMEER-CEM**

**31.1** No bidder shall contact SAMEER-CEM or concerned scientist on any matter relating to its bid, from the time of the bid opening to the time the Contract is awarded. If the bidder wishes to bring additional information to the notice of SAMEER-CEM, it should do so in writing.

**31.2** Any effort by a bidder to influence SAMEER-CEM in its decisions on bid evaluation, bid comparison or contract award may result in rejection of the Bidder's bid.

## **32. Post qualification**

**32.1** In the absence of pre-qualification, SAMEER-CEM will determine to its satisfaction whether the Bidder that is selected as having, submitted the lowest evaluated responsive bid is qualified to perform the contract satisfactorily.

**32.2** The determination will take into account the eligibility criteria listed in the bidding documents and will be based upon an examination of the documentary evidence of the Bidder's qualifications submitted by the Bidder, as well as such other information as the Purchaser deems necessary and appropriate.

## SECTION-F: PAYMENT TERMS

### **33. Payment Terms**

**33.1 Payment for Indigenous supplier:** 100% payment would be released after satisfactory installation as certified by the user Scientists, subject to submission of Performance Bank Guarantee (PBG) for 3 % of the purchase order value, covering the period of Warranty+60days.

a) Successful bidder is requested to furnish the following details for making payment.

- (i) 11 digit core banking Account Number.
- (ii) Type of Account (Saving/Current)
- (iii) Name of Account Holder
- (iv) Name of Bank & Branch
- (v) IFSC Code Number
- (vi) MICR Number

### **33.2 Payment for Foreign Suppliers:**

**(a) 100%** payment by Irrevocable Foreign Letter of Credit subject to submission of Performance Bank Guarantee (PBG) by the vendor for 3% of the purchase order value covering the period of warranty + 60 days within 21 days of placement of purchase order and before opening Irrevocable Letter of Credit (LC)

**(b)** Agency Commission, if any, will be paid in Indian Rupees to the Indian Agent.

**33.3** No outright advance payments will be made to the firms.

**(i)** No extra charge will be paid by SAMEER-CEM, Supplier will take care for all transit risks for the safe delivery of the item.

**(ii)** The L/C will be confirmed at the suppliers cost, if requested specifically by the supplier. **All bank charges abroad shall be to the account of the beneficiary i.e. supplier and all bank charges in India shall be to the account of the opener i.e. purchaser.** If L/C is requested to be extended/ reinstated for reasons not attributable to the purchaser, the charges thereof would be to the suppliers' account. Payment of local currency portion shall be made in Indian Rupees within thirty (30) days of presentation of claim supported by a certificate from the Purchaser declaring that the Goods have been delivered and that all other contracted Services have been performed.

## SECTION - G: PENALTY CLAUSE

### **34. Penalty clauses: -**

**34.1** Penalty (Liquidated Damages) @ 0.5% of basic price per week will be deducted from Manufacturer's/ Indian Agent's Bill for delay in Delivery & Despatch beyond Delivery dates (as extended by SAMEER-CEM in Purchase Order and Letter of Credit Schedule). Maximum deduction for failing to deliver within SAMEER-CEM approved delivery period & extensions will be limited to 5% of Ex-works Value (equivalent in Indian Rupees) for non-fulfilment of delivery deadlines and any other contractual obligations as per Purchase Order. Once the maximum is reached, SAMEER-CEM may consider termination of the Contract.

**34.2** Delay in Installation beyond contractual deadline will result in forfeiture of EMD and Performance Bank Guarantee.

**34.3** For any clarification, please mail at [purchase.chn.sameer@nic.in](mailto:purchase.chn.sameer@nic.in)

**34.4 Corrigenda:** Corrigenda, if any, to this tender will be published on our website <http://cem.sameer.gov.in>. The bidders are advised to check our website before submitting the bid.

### **34.5 PERFORMANCE GUARANTEE**

The successful bidder has to give Performance Bank Guarantee (PBG) in the form of Demand Draft / Fixed Deposit Receipt from an Indian nationalized bank / Bank Guarantee from an Indian nationalized bank / a counter Letter of Credit (LC) from our bankers (in case of foreign order), for 3 % of Order Value. Performance Bank Guarantee should remain valid for a period of sixty days beyond the warranty period.

### **34.6 SAMEER-CEM Clearing Agent in India for imported consignment**

M/s. Balmer Lawrie & Co Ltd.,  
628, Anna Salai, Teynampet,  
Chennai-600 018, Tamil Nadu, India  
Phone 91-44- 24302463 - 24348104  
E-mail: [thiyagarajan.j@balmerlawrie.com](mailto:thiyagarajan.j@balmerlawrie.com)  
[baskar.m@balmerlawrie.com](mailto:baskar.m@balmerlawrie.com)  
Mobile: 9940015440 / 9551324005

### **34.7 Delivery & Documents:**

Details of Shipping and other Documents to be furnished by the Supplier are

#### **(i) For Goods manufactured within India**

Within 24 hours of dispatch, the supplier shall notify SAMEER-CEM the complete details of dispatch and also supply following documents by registered post / speed post and copies thereof by FAX or e-mail.

#### **(ii) For Goods manufactured abroad**

- (a) Two copies of supplier's Invoice giving full details of the goods including quantity, value, etc.;
- (b) Packing list;
- (c) Certificate of country of origin;
- (d) Manufacturer's guarantee and Inspection certificate;

#### **Note:**

1. The nomenclature used for the item description in the invoices(s), packing list(s) and the delivery note(s) etc. should be identical to that used in the contract. The dispatch particulars including the name of the transporter should also be mentioned in the Invoice(s)
2. The above documents should be received by the Purchaser before arrival of the Goods and, if not received, the Supplier will be responsible for any consequent expenses

### **34.8 Insurance:**

- (i) Insurance liabilities will be as per the basis of delivery point/INCOTERMS as mentioned in the purchase order in case of imported items. Accordingly, SAMEER-CEM will arrange the Insurance Coverage of the item on its own cost.
- (ii) Insurance charges will be borne by SAMEER-CEM if it is specifically mentioned in the Purchase Order in case of Indigenous Supply (Supplier within India). If it is not mentioned, then Insurance liabilities will be in Supplier's account.

## Cover - I (Technical Bid)

### TECHNICAL BID

#### Technical Specification of mmWave(60GHz) Measurement system

S.No	Parameter	Specification
1.	Frequency Range with Harmonic Mixer	50 GHz to 75 GHz
2.	Frequency counter resolution	0.01Hz
3.	RF Input Connector(Mixer )	WR15 (UG385/U)
4.	1 dB input Mixer Compression (full frequency range)	$\geq -5$ dBm
5.	Max RF Input Level	+10 dBm
6.	Displayed Average Noise Level 50 GHz to 75 GHz( normalized to 1 Hz BW)	-130 dBm or better
<b>Bandwidth Parameters</b>		
7.	Resolution Bandwidth	1 Hz to 8 MHz
8.	Video Bandwidths	1 Hz to 8 MHz
9.	Analysis Bandwidth	25 MHz (upgradable upto 510MHz)
<b>Sweep Parameters</b>		
10.	Sweep time range	1 ms to 4000 s
11.	Sweep Trigger	Free run, External, Video
<b>Measurement Capability</b>		
12.	Spectrum Measurement	Carrier to Noise Ratio, Adjacent Channel power ratio, OBW
13.	Vector Signal Analysis	<b>Modulation format:</b> FSK, MSK, BPSK, QPSK, QAM <b>Measurement display result:</b> IQ Constellation, EVM, Eye diagram, Symbol table in Hexadecimal or Binary <b>Filter types:</b> Root cosine, Raised Root Cosine, Rectangle, Gauss
14.	Phase Noise CF @ 60 GHz for offsets	1 KHz: <-77 dBc/Hz
		10 KHz: <-82 dBc/Hz
		1 MHz: <-97 dBc/Hz
<b>Measuring(Analyser) Unit Specs</b>		
15.	Trace Detectors	Normal, Peak, Sample, RMS,

		Average
16.	Microwave Preselector Bypass	Should be available
17.	LO/IF connections for connecting external mixers	Should be available
18.	LO output frequency range(GHz)	To be provided
19.	LO output level	
20.	LO/IF Connector type	SMA (F)
21.	IF input frequency range(GHz)	To be provided
22.	IF input maximum level	
23.	IF input damage level	
24.	IF connector type	
25.	Aging per year	1 x 10-6 / year
26.	Temperature Stability (0 °C to +50 °C)	1 x 10-6
27.	Reference frequency output	10 MHz, 0 dBm, 50 Ω, BNC Female
28.	External Reference frequency input	10 MHz, 0 dBm, 50 Ω, BNC Female
29.		
<b>Interface Parameters</b>		
30.	Interface	LAN, USB
31.	Display	LCD colour display 1280 x 800 touch screen
<b>General Parameters</b>		
32.	Power Supply	230V AC, 50 Hz
33.	Operating temperature	0° to +40° C
34.	Storage Temperature	-40 °C to +70 °C
35.	Internal Hard drive	SSD ≥50 GB
36.	EMI/EMC	Should be complied

**mmWave(60GHz) Measurement system block diagram**

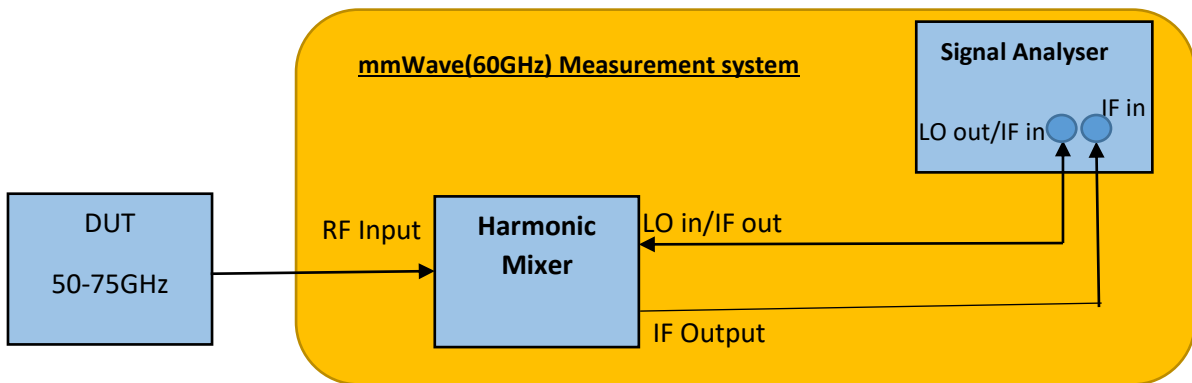

**Technical Bid shall include the following**

- a. Bid (EMD) security declaration form
- b. Tender fee as specified in the invitation to bids
- c. Service Support Details Form
- d. Deviation Statement Form
- e. Technical Specification Compliance Form
- f. Manufacturer's Authorization Letter
- g. Bidder's Performance Statement Form
- h. Equipment Data sheet/Technical specification
- i. Tender Acceptance Letter-Annex-VII (*duly signed by the bidder with company seal*).
- j. Bidders Eligibility Certificate-Annex-VIII (*duly signed by the bidder with company seal*).

I/We certify that all the terms and conditions of the tender documents are acceptable to us.

Signature of the authorized person

Name:

Designation :

Company Seal

Date :

Place :



**Cover-II (Price )**

**Format for Price Bid** (Bidder is required to submit the price bid in the given format on their LETTER HEAD

ITEM	DESCRIPTION	QUANTITY	PRICE IN INR	PRICE IN (Name of the currency)
I	Millimeter wave (60 GHz) Measurement System	One		
II				
III				
IV				
V	<b>OTHER CHARGES</b>			
1.	<b>TAXES AND DUTIES APPLICABLE ON ITEMS</b>			
	I			
	II			
	III			
	IV			
2.	<b>FREIGHT</b> from bidder's manufacturing facility to SAMEER, Chennai, India			
3.	<b>INSURANCE</b>			
4.	<b>OCTROI</b>			
5.	<b>ADDITIONAL CHARGES IF ANY</b>			
	<b>TOTAL AMOUNT</b>			
	<b>TOTAL AMOUNT (IN WORDS)</b>			

Signature of the Manufacturer/authorized agent

Name :

Company Seal:

Date :

Place:

ANNEXURE -I

MANUFACTURER'S AUTHORIZATION LETTER

Dated-----

To  
The Programme Director  
SAMEER-Centre for Electromagnetics  
CIT Campus, 2<sup>nd</sup> Cross Road,  
Taramani  
Chennai - 600 113  
INDIA.

Dear Sir:

We \_\_\_\_\_ who are established and reputed manufacturers of having factories at \_\_\_\_\_ (*address of factory*) do hereby authorize M/s. \_\_\_\_\_ (*Name and address of Agent*) to submit a bid, negotiate and receive the order from you against your tender No. TENDER No. S-CEM/OTE/MCAD/3043/141-1/2020-2021/10666 for the supply and Installation of Millimeter wave (**60 GHz**) Measurement System. No company or firm or individual other than M/s \_\_\_\_\_ is authorized to bid and conclude the contract in regard to this business.

We hereby extend our full guarantee and warranty as per the requirement of SAMEER-CEM mentioned in the tender document for the goods and services offered by the firm.

Yours  
faithfully,

(Name)

(Name of  
manufacturers)

**Note:** This letter of authority should be on the **letterhead of the manufacturer** and should be signed by a person competent and having the power of attorney to bind the manufacturer. It should be included by the Bidder in its techno-commercial un priced

**ANNEXURE -II**

**BIDDER'S PERFORMANCE STATEMENT FORM**

**(For a Period of Last 5 Years)**

Order placed by (full address of purchaser)	Description and quantity of ordered similar equipment	Order No and Date	Price	Date of Completion of delivery as per Contract/ Actual	Remarks indicating reasons for late delivery, if any	Has the equipment been installed satisfactory?	Contact Person along with Tel.No., Fax No. & e-mail address

Name of the bidder .....

Signature & Seal

Date :

Place:

**ANNEXURE-III**

**SERVICE SUPPORT DETAILSFORM**

<b>S.N.</b>	<b>Nature of training imparted</b>	<b>List of similar type equipment's services in the past 3 years or as per Tender Enquiry/Document</b>	<b>Address, Telephone Nos., Fax and email address of the firm located in India</b>	<b>Value of minimum stock of consumable spares held at all times</b>

**Signature and Seal of the manufacturer/Bidder .....**

**Place:**

**Date:**

**ANNEXURE-IV**

**DEVIATION STATEMENT FORM**

The following are the particulars of deviations from the requirements of the tender document and specifications:

<b>CLAUSE</b>	<b>DEVIATION</b>	<b>REMARKS (INCLUDING JUSTIFICATION)</b>

**Signature and Seal of the Manufacturer/Bidder**

**Place:**

**Date:**

**NOTE:**

Where there is no deviation, the statement should be returned duly signed with an endorsement indicating "No Deviation"

**ANNEXURE-V**

**TECHNICAL SPECIFICATION COMPLIANCE STATEMENT FORM**

An item-by-item commentary on the SAMEER-CEM Technical Specifications demonstrating substantial responsiveness of the equipment's to those specifications or a statement of deviations and exceptions to the provisions of the Technical Specifications. (Technical literature/brouchers/manuals should be attached along with this format)

ITEM NAME	Millimeter wave (60 GHz) Measurement System		
Sl.No	Tender Specifications	Bidder's Specifications	Remarks/Deviation if any

*(Technical literature/brouchers/manuals should be attached along with this format)*

**Please note:**

1. Compliance statement should compare/comparing the specifications of the quoted model to the required specifications. This statement should also give the page number(s) of the technical literature where the relevant specification is mentioned.
2. Bids must have supporting documents (technical literature or copies of relevant pages from the service manual or factory test data) for all the points noted above, failure regarding which may result in rejection of bid.

Signature of the authorized person

Name:

Designation :

Company Seal :

Date :

Place :

## Annexure-VI

### TENDER ACCEPTANCE LETTER (To be given on Company Letter Head)

Date:

To,

The Programme Director,  
Society for Applied Microwave Electronics Engineering and  
Research(SAMEER) -  
Centre for Electromagnetics, CIT Campus, 2nd Cross Road, Taramani,  
Chennai - 600 113, Tamil Nadu, India.

Sub: Acceptance of Terms & Conditions of Tender.

Tender Reference No: S-CEM/OTE/MCAD/3043/141-1/2020-2021/10666

Name of Tender:- **Supply and Installation of Millimeter Wave (60 GHz)  
Measurement System.**

Dear Sir,

1. I/ We have downloaded/obtained the tender document(s) for the above mentioned tender from the web site(s) namely:

- i. <http://cem.sameer.gov.in>
- ii. <https://eprocure.gov.in/cppp>

as per your advertisement, given in the above mentioned website(s).

2. I/We hereby certify that I /we have read the entire terms and conditions of the tender documents from Page No. 1 to 34 (including all documents like annexure(s), schedule(s), etc, which form part of the contract agreement and I /we shall abide hereby by the terms/conditions/clauses contained therein.

3. The corrigendum(s) issued from time to time by SAMEER-CEM too have also been taken into consideration, while submitting this acceptance letter.

4. I/We hereby unconditionally accept the tender conditions of above mentioned tender document(s) /corrigendum(s) in its totality/entirety.

5. I/We do hereby declare that our Firm has not been blacklisted/ debarred by any Govt.Department/Public sector undertaking.

6. I/We certify that all information furnished by our firm is true & correct and in the event that the information is found to be incorrect/untrue or found violated, then SAMEER-CEM shall without giving any notice or reason therefore or summarily reject the bid or terminate the contract, without prejudice to any other rights or remedy including the forfeiture of the full said earnest money deposit absolutely.

Yours faithfully,

(Signature of the Bidder, with Company Seal)



**Annexure-VII**

**Eligibility of Bidder**

*(As per the OM No. 6/18/2019-PPD dated 23.07.2020 issued by the Department of Expenditure, Public Procurement Division, Ministry of Finance, Government of India)*

**I/We have read clause regarding restrictions on procurement from a bidder of a country which shares a land border with India. I/We hereby certify that this bidder is not from such a country and eligible to be considered".**

Yours faithfully,

(Signature of the Bidder, with Company Seal)

*(To be given on Company Letter Head)*

**Annexure-VIII**

*(To be given on Company Letter Head)*

**Bid Security (EMD) Declaration**

This is to undertake that if we withdraw or modify our bid during the period of validity, or if we are awarded the contract and we fail to sign the contract, or to submit a performance security before the deadline defined in the tender document, we will be suspended for the period of time specified in the tender document from being eligible to submit Bids with SAMEER-CEM.

Yours faithfully,

(Signature of the Bidder, with Company Seal)